

# ON THE THEORY OF COMPLICATED SYSTEMS OF GYROSCOPIC STABILIZATION

(K TEORII SLOZHNYKH SISTEM GIROSKOPICHESKOI  
STABILIZATSII)

*PMM Vol. 22, No. 3, 1958, pp. 359-375*

A. Iu. ISHLINSKII  
(Moskva)

*(Received 14 February 1958)*

For obtaining the equations of motion of complicated gyroscopic devices, prerogative is given to the second method of Lagrange. While giving credit to this method for leading us seemingly automatically to our goal, we cannot fail to notice its extremely cumbersome nature, obscuring sometimes even the mechanical meaning of the equations obtained.

At the same time the equations of motion of a complicated gyroscopic device can be obtained in a relatively simple way by a successive application of the theorem of kinetic moment (i.e. the theorem of *quantitas motus*), [principle of angular momentum], to the corresponding mechanical system as a whole and to its separate parts. The description of an appropriate method for the case of a particular system of regulated stabilization constitutes the basic contents of the present paper.

1. The motion of gyroscopic systems to be stabilized, after a certain transient process, reduces itself, as a rule, to a slow change of orientation of the spin axis of the gyroscopes with respect to the fixed stars. Such a motion is usually called precession.

In the investigation of the precessional motion, the kinetic moments of the elements of suspension of a gyroscopic system and of the inner gimbals of its gyroscopes, as well as the equatorial components of the kinetic moments of the rotors themselves and the kinetic moments of the motors need not be taken into consideration. The polar components (directed along the spin axis of the corresponding gyroscope) can be considered as being equal to the product of the axial moment of inertia of the rotor of the gyroscope and the angular velocity of the rotor with respect to its inner gimbal.

The above-mentioned assumptions lead us to the so-called precessional

or elementary theory of gyroscopic phenomena. Under these assumptions the corresponding differential equations can be considerably simplified. In particular, their order can be reduced. At the same time the accuracy of the results obtained, investigating precessional motions, turns out to be completely satisfactory, except in special cases when the influence of inertia of the gimbals of a Cardan suspension must be taken into account.

Investigation of the transient processes in gyroscopic systems is possible only if the kinetic moments of all the parts of the device are taken into account. The equations of the precessional theory for this purpose are of no use.

2. Using the theorem of kinetic moment for obtaining the differential equations of motion of a gyroscopic device, one must have complete information about the structure of the mechanical system in as much as the derivative of the kinetic moment vector of the system is the object to be investigated.

In this connection the kinetic moment and its derivative must be referred with respect to some well defined coordinate system  $\xi^*\eta^*\zeta^*$  which is in a state of translatory motion. In what follows such a system will be called a coordinate system of support. Indeed with respect to such a system one must calculate the inertia forces of the constrained motion acting on the mechanical system under consideration. In view of the translatory nature of the motion of the above mentioned coordinate system of support, the inertia forces of the constrained motion reduce themselves to a resultant vector. The line of action of this vector passes through the center of gravity of the mechanical system. Its direction is opposite to the direction of the acceleration of the origin of the coordinate system of support with respect to the so-called absolute coordinate system  $\xi_a^*\eta_a^*\zeta_a^*$ . The origin of the latter is at the center of mass of our solar system with the axes directed towards the fixed stars.

The magnitude of the resultant inertia force of the constrained motion is equal, of course, to the product of the mass of the considered mechanical system and the just mentioned acceleration.

As a coordinate system of support can be taken, in general, any coordinate system  $\xi\eta\zeta$ , not necessarily in a translatory state of motion. However, if the coordinate system of support  $\xi\eta\zeta$  is in a state of rotation with respect to the absolute coordinate system  $\xi_a^*\eta_a^*\zeta_a^*$ , then taking account of the inertia forces of the constrained motion becomes considerably more complicated. In addition, the Coriolis inertia forces appear which must be included among the external forces acting on the mechanical system under consideration.

When the coordinate system of support is in a state of translation, the Coriolis inertia forces, of course, are absent.

3. Let a certain coordinate system  $\xi^*\eta^*\zeta^*$  be chosen as a system of support, and let  $G$  denote the kinetic moment of the mechanical system under consideration with respect to this coordinate system. The coordinate system  $\xi^*\eta^*\zeta^*$  moves translatory, and therefore according to the theorem of kinetic moment the relations

$$\frac{dG_{\xi^*}}{dt} = M_{\xi^*}, \quad \frac{dG_{\eta^*}}{dt} = M_{\eta^*}, \quad \frac{dG_{\zeta^*}}{dt} = M_{\zeta^*} \quad (1)$$

hold.

The left-hand sides of these relations contain the derivatives, with respect to time, of the projections of the kinetic moment vector  $G$  along the axes  $\xi^*$ ,  $\eta^*$  and  $\zeta^*$ , while the right-hand sides contain the sums of the moments with respect to the same axes of all the external forces acting on the mechanical system under consideration, including the inertia forces of the constrained motion.

In applications, the relations (1) are not of much use because of the extremely cumbersome nature of the equations obtained. A considerable simplification of exposition is achieved by calculating the projections of the derivative of the kinetic momentum along the axes of a certain specially chosen moving coordinate system, the motion of which is in one or another way connected with the motion of the mechanical system under consideration.

Let  $xyz$  be one such coordinate system called auxiliary or computational. Denote by  $\omega$  the angular velocity of this new coordinate system with respect to the coordinate system of support  $\xi^*\eta^*\zeta^*$ , and assume that the origins of both systems coincide. The projections of the derivative of the kinetic moment vector of the mechanical system under consideration with respect to the coordinate system of support  $\xi^*\eta^*\zeta^*$  along the coordinate axes  $x, y$  and  $z$  have the well-known expressions

$$\frac{dG_x}{dt} + \omega_y G_z - \omega_z G_y, \quad \frac{dG_y}{dt} + \omega_z G_x - \omega_x G_z, \quad \frac{dG_z}{dt} + \omega_x G_y - \omega_y G_x \quad (2)$$

where  $G_x$ ,  $G_y$  and  $G_z$  are the projections of the kinetic moment vector along the same axes, and  $\omega_x$ ,  $\omega_y$  and  $\omega_z$  are the components of the angular velocity of the system  $xyz$  with respect to the supporting system  $\xi^*\eta^*\zeta^*$  or, what is the same, with respect to the absolute coordinate system  $\xi_a^*\eta_a^*\zeta_a^*$ .

Due to the theorem of kinetic moment the expressions (2) are equal to the sums of the moments of the above-mentioned external forces of the mechanical system under consideration, together with the inertia forces,

depending on the constrained motion of the supporting coordinate system  $\xi^*\eta^*\zeta^*$  (but by no means of the auxiliary system  $xyz$  which has a purely kinematic assignment; in this system the calculation of the derivative of the kinetic moment as it changes with respect to the coordinate system of support  $\xi^*\eta^*\zeta^*$  may turn out to be much simpler than with respect to the system  $\xi^*\eta^*\zeta^*$  itself). Denoting the sums of these moments by  $M_x$ ,  $M_y$  and  $M_z$ , we obtain the relations

$$\begin{aligned} \frac{dG_x}{dt} + \omega_y G_z - \omega_z G_y &= M_x, & \frac{dG_y}{dt} + \omega_z G_x - \omega_x G_z &= M_y \\ \frac{dG_z}{dt} + \omega_x G_y - \omega_y G_x &= M_z \end{aligned} \quad (3)$$

the set of which is equivalent to the set of relations (1).

4. Among the external forces acting on mechanical systems are the unknown forces of reaction of the platform (usually moving) supporting them. In the majority of cases, gyroscopic systems are connected with the supporting platform by means of Cardan suspensions. Therefore, if the mechanical system under consideration consists of several elements of the given gyroscopic device, for example, of the whole system without the outer gimbal, or of a separate gyroscope with its inner gimbal and the rotor, then, as a rule, the outer connection of the system is a simple pivot hinge. In a number of cases it can be assumed that, to a certain degree of approximation, the moment of friction in the pivot hinge does not depend on the normal reactions of its axle bearings. If the axle of the pivot hinge coincides with an axis of the coordinate system  $xyz$ , then one of the relations (3) changes into the equation of motion of a gyroscopic system which does not contain the unknown normal reaction forces of connection.

In a more complicated case, when the axle of the pivot hinge does not coincide with any of the coordinate axes  $x$ ,  $y$  or  $z$ , the equation of motion of a gyroscopic system which does not contain normal reactions assumes the form

$$\begin{aligned} \left[ \frac{dG_x}{dt} + \omega_y G_z - \omega_z G_y \right] \cos x\nu + \left[ \frac{dG_y}{dt} + \omega_z G_x - \omega_x G_z \right] \cos y\nu + \\ + \left[ \frac{dG_z}{dt} + \omega_x G_y - \omega_y G_x \right] \cos z\nu = M_\nu \end{aligned} \quad (4)$$

Here  $\cos x\nu$ ,  $\cos y\nu$ , and  $\cos z\nu$  are cosines of the angles, made by the axis  $\nu$  of the pivot hinge with the  $x$ -,  $y$ - and  $z$ -axis, respectively, and  $M_\nu$  denotes the sum of the moments of the external forces, acting on the mechanical system under consideration, with respect to the axle of the pivot hinge.  $M_\nu$  contains also the moment of friction of the axle of the pivot hinge, the moment of torsion transmitted to this axle by means

of a special device, for example, an electric motor, and the moments of inertia forces of the constrained motion with respect to the axle  $\nu$ , depending on the translatory motion of the coordinate system of support  $\xi^* \eta^* \zeta^*$ . In a formal sense it is self-evident that

$$M_\nu = M_x \cos x\nu + M_y \cos y\nu + M_z \cos z\nu \quad (5)$$

If, however, the moment of friction of the axle of the pivot hinge depends on the normal reactions, then the establishment of the equation of motion, not containing these unknown reactions, becomes a more complicated problem and requires the use of all three relations of (3). Let us observe that by means of the Lagrangian method, (introducing undetermined multipliers), it would be rather difficult to establish the equations of motion of a gyroscopic system which takes into account the friction depending on the magnitudes of the normal reactions.

5. Let us proceed now to the establishment of the equations of motion of a compound gyroscopic device, namely, a system of spatial stabilization by means of three gyroscopes\* (Fig. 1).

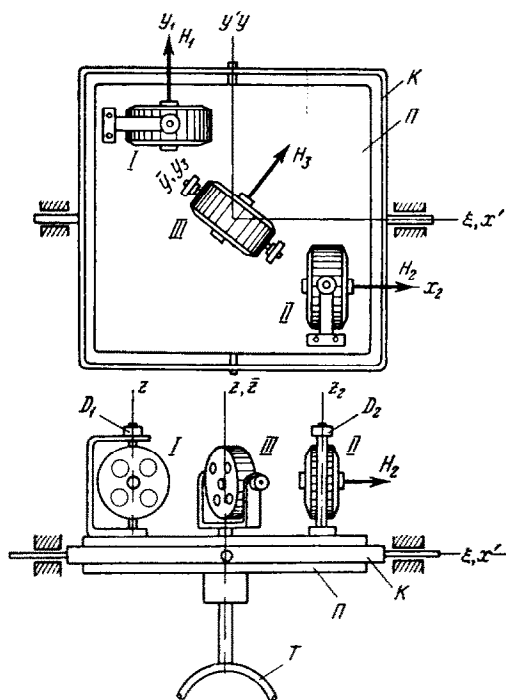

Fig. 1.

\* Such a system was, in particular, realized by the Academy of Sciences of the Ukrain. Soviet Socialist Republic in 1957 for the stabilization of frames of electrometers on moving supports (gyroplane).

On a moving support, carrying this device, are fastened the bearings of the  $\xi$  ( $x'$ )-axis of the Cardan suspension ring  $K$  of the platform  $\Pi$ . The platform  $\Pi$  may turn with respect to the ring  $K$  about the  $y'$  ( $y$ )-axis, lying in the plane of the ring  $K$  and making a right-angle with the  $\xi$  ( $x'$ )-axis. On the platform  $\Pi$  are placed two gyroscopes  $I$  and  $II$ , whose inner gimbals may rotate with respect to this platform about the  $z_1$ - and  $z_2$ -axis respectively, both at right-angles to the plane of the platform.

The body  $T$  to be stabilized, together with the third gyroscope  $III$ , can also turn with respect to the platform  $\Pi$  about an axis  $z$  ( $z$ ) at right-angles to the plane of this platform. The  $y_3$ -axis of the inner gimbal of the gyroscope  $III$  is parallel to the plane of the platform  $\Pi$ .

Let us introduce right-hand coordinate systems  $\xi\eta\zeta$ ,  $x'y'z'$ ,  $xyz$  and  $\bar{x}\bar{y}\bar{z}$ , connected with the moving support, the ring  $K$ , the platform  $\Pi$  and the body  $T$  to be stabilized, respectively. In what follows, the coordinate system  $xyz$  will be taken as the computational reference system. The  $\xi$ -axis of the coordinate system  $\xi\eta\zeta$  is the longitudinal axis of the moving object (moving support) and the  $\eta$ -axis its transverse axis. The  $x'$ - and  $y'$ -axis of the coordinate system  $x'y'z'$  lie in the plane of the ring  $K$ ; the  $x'$ -axis coincides with the  $\xi$ -axis and is the axis of rotation for  $K$  with respect to the object (Fig.2).

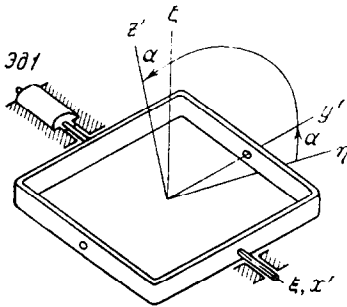

Fig. 2.

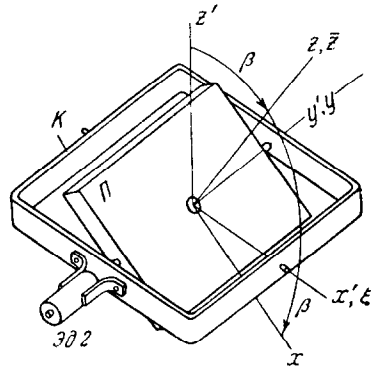

Fig. 3.

Denote by  $a$  the angle of rotation of the ring  $K$  with respect to the object. For  $a = 0$ , the corresponding axes of the two coordinate systems  $x'y'z'$  and  $\xi\eta\zeta$  coincide. For  $a > 0$  the ring  $K$  is rotated with respect to the object in the counterclockwise sense, when the observation of the rotation is made from the side of the positive direction of the  $\xi$ -axis (or, what is the same, of the  $x'$ -axis).

The coordinate system  $xyz$  is connected with the platform  $\Pi$  (Fig.3). The  $y$ -axis of this system coincides with the  $y'$ -axis and is the axis of rotation of the platform  $\Pi$  with respect to the ring  $K$ . Denote this angle

of rotation by  $\beta$ . The  $x$ -axis of the coordinate system  $xyz$  lies in the plane of the platform and the  $z$ -axis is at right-angles to this platform. For  $\beta = 0$ , the planes of the platform  $\Pi$  and of the ring  $K$  and the corresponding axes of the coordinate systems  $xyz$  and  $x'y'z'$  coincide. For  $\beta > 0$ , the platform  $\Pi$  is rotated in the counterclockwise sense with respect to the ring  $K$ , when the rotation is observed from the side of the positive direction of the  $y$ -axis (or, what is the same, the  $y'$ -axis).

Finally, the body  $T$  to be stabilized is connected with the coordinate system  $xyz$ , the  $z$ -axis of which coincides with the  $z$ -axis of the coordinate system  $xyz$ , connected with the platform  $\Pi$ . Denote by  $\psi$  the angle of rotation of these two systems with respect to each other (Fig.4). For  $\psi = 0$

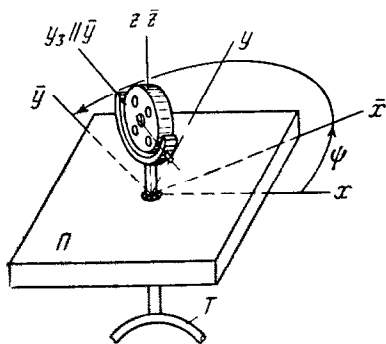

Fig. 4.

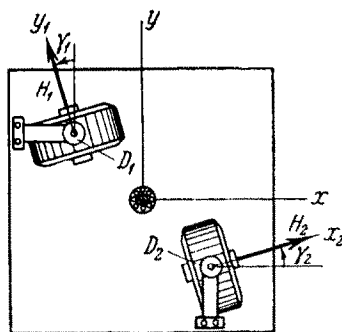

Fig. 5.

the  $x$ - and  $\bar{x}$ -axis, and also the  $y$ - and  $\bar{y}$ -axis coincide with each other. For  $\psi > 0$  the body  $T$  is rotated with respect to its initial position in a counterclockwise sense, when the rotation is observed from the side of the positive direction of the  $z(\bar{z})$ -axis.

Denote by  $\gamma_1$  and  $\gamma_2$ , respectively, the angles of rotation of the inner gimbals of the gyroscopes  $I$  and  $II$  with respect to the platform  $\Pi$ . For  $\gamma_1 = 0$ , the axis of proper rotation [spin] of the gyroscope  $I$  is parallel to the  $y$ -axis. Analogously for  $\gamma_2 = 0$  the axis of spin of the gyroscope  $II$  is parallel to the  $x$ -axis. Let the positive direction for the angles  $\gamma_1$  and  $\gamma_2$  be the same as for the angle  $\psi$ .

Finally, denote by  $\delta$  the angle between the axis of spin of the gyroscope  $III$  and the plane of the platform (Fig.6). The positive direction of the angle  $\delta$  will be selected in such a way that for  $0 < \delta < \pi/2$  the projection of the proper kinetic moment of the gyroscope  $III$  on the  $z(\bar{z})$ -axis is positive.

6. To secure prolonged stabilization of the body  $T$  in the above described device, certain auxiliary elements besides the gyroscopes have

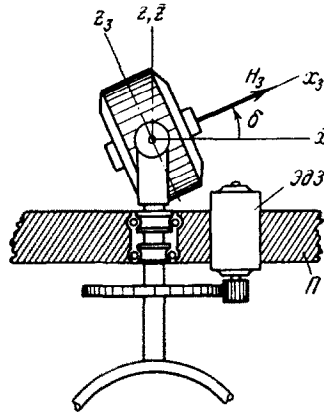

Fig. 6.

to be anticipated. These elements must impose on the ring  $K$ , the platform  $\Pi$  and the body  $T$  moments, the magnitudes and directions of which are determined by the angles  $\gamma_1$ ,  $\gamma_2$  and  $\delta$ . Such elements may be, in particular, the electromotors  $E_1$ ,  $E_2$  and  $E_3$  (Fig. 2, 3 and 6). The electromotor  $E_1$  is mounted on the moving support. This motor develops about the  $\xi(x')$ -axis a moment  $M_x$ , applied at the Cardan ring  $K$ . The operation of the electromotor is governed by an amplifier, whose voltage is produced by a transmitter  $D_1$ , mounted on the axis of the inner gimbal of the gyroscope  $I$ . The precession of the gyroscope  $I$  caused by the moment of the electromotor  $E_1$  is directed in the sense in which the angle  $\gamma_1$  decreases. By the same token, for a sufficiently large moment of this electromotor, the danger is removed that the angle  $\gamma_1$  could reach the value  $\pi/2$  at which the stabilization breaks down. The latter case can happen when the device together with its moving support, is turned about the  $z$ -axis or by some other cause (action of weight, friction, inertial loads, and others).

The electromotor  $E_2$  is mounted on the ring  $K$ , by means of which the moment  $M_y$  along the  $y^2(y)$ -axis is applied to the platform  $\Pi$ . The operation of the electromotor  $E_2$  is governed analogously to the preceding case by a transmitter  $D_2$ , which indicates the angle of rotation  $\gamma_2$  of the inner gimbal of the gyroscope  $II$ .

Finally, the electromotor  $E_3$ , which is mounted on the platform  $\Pi$ , tends to rotate the body  $T$  about the  $z(z)$ -axis, developing a moment, whose magnitude and direction is determined by the angle  $\delta$  of declination of the inner gimbal of the gyroscope  $III$  (Fig. 6).

Change of orientation of the body  $T$  can arise only as a result of action of forces, applied to the gyroscopes  $I$ ,  $II$  and  $III$  about their axes of inner gimbals. Such forces may be, in particular, the friction forces, which will change the given orientation of the body  $T$ . In order



to re-establish this orientation by means of electromagnets, and in a number of cases also by means of gravity forces, moments are produced artificially about the axes of the inner gimbals of the gyroscopes *I*, *II* and *III*.\*

7. In establishing the equations describing the behaviour of this compound gyroscopic device, let us consider in succession the following six mechanical systems: (1) the whole device, i.e. the ring *K*, the platform *Π*, the body *T* and all three gyroscopes with all the additional elements which are kinematically connected with them, (2) the same device, but without the ring *K*, (3) the body *T* with the gyroscope *III*, (4) the gyroscope *I* (the rotor together with the inner gimbal), (5) the gyroscope *II*, and finally, (6) the gyroscope *III*.

Each of the above mentioned systems is connected with others or with the moving support by means of a plane pivot hinge. The moment of the external forces acting on the corresponding system with respect to the axle of the pivot hinge must be considered as given.

The angle of rotation of the hinge pivots with respect to their bearings is one of the generalized coordinates of the device. This fact also explains the choice of the above mentioned mechanical systems.

For the first three mechanical systems take as the supporting coordinate system  $\xi^*\eta^*\zeta^*$  a system with the origin at the geometric center of support, i.e. the common origin of the coordinate systems  $\xi\eta\zeta$ ,  $x'y'z'$ ,  $xyz$  and  $\bar{x}\bar{y}\bar{z}$ , connected respectively with the moving support by the ring *K*, the platform *Π* and the body *T*. The origins of the supporting coordinate

\* Similar moments may place the platform into the plane of the horizon, and produce for the gyroscope *III* such a precession that the body *T* does not rotate with respect to the Earth. For this purpose a properly selected load can be mounted on the inner gimbal of the gyroscope *III*, producing a moment about the axis  $y_3$  of this gimbal. In order to bring the platform into the position of the plane of the horizon, it is sufficient, in particular, to attach to the inner gimbals of the gyroscopes *I* and *II* some additional loads. When the platform is inclined, the additional loads will create moments about the axes of the inner gimbals, and by the same token produce precession of the gyroscopes *I* and *II*. By a proper choice of the position of the loads on the inner gimbals, the platform will return back to its horizontal position. The described correcting system is called a mechanical one. It is simpler than the so-called electric correcting system, where the moments along the axes of the inner gimbals of the gyroscopes *I* and *II* are imposed by means of electromagnets. The magnitude and direction of the moments are determined by deviations of special pendulums situated on the platform *Π*.

systems for the last three mechanical systems, i.e. the separate gyroscopes, will be taken at the points of intersection of the axes of the inner gimbals and rotors of the corresponding gyroscope.

As a computational system assume in all cases one and the same coordinate system  $xyz$  which is fixed with the platform  $\Pi$ . As above, denote the angular velocity of this system, or, what is the same, of the platform  $\Pi$  with respect to the supporting coordinate system  $\xi^*\eta^*\zeta^*$  by  $\omega$ , and its projections on the  $x$ -,  $y$ - and  $z$ -axis by  $\omega_x$ ,  $\omega_y$  and  $\omega_z$ . The magnitudes of the projections  $\omega_x$  and  $\omega_y$  are determined by the precession of the gyroscopes  $I$  and  $II$  and consequently must be small. Concerning the projection of the angular velocity of the platform  $\Pi$  on the  $z(\bar{z})$ -axis, i.e. the projection  $\omega_z$ , we can say that its magnitude is determined by the motion of the support carrying the stabilizer under consideration, and consequently may be arbitrary.

8. Denote by  $M'$  the resultant moment of forces acting on the first mechanical system.\*

Further denote the kinetic moment [angular momentum] of the first mechanical system by  $G'$ . Corresponding to what has been said above, in the framework of the elementary theory of gyroscopes,  $G'$  must be considered as consisting only of the geometric sum of the proper kinetic moments of the gyroscopes  $I$ ,  $II$  and  $III$ .

The projections of the kinetic moment  $G'$  on the axes of the computational coordinate system  $xyz$  are given by the expressions

$$\begin{aligned} G_x' &= H (-\sin \gamma_1 + \cos \gamma_2 + \cos \delta \cos \psi), \\ G_y' &= H (\cos \gamma_1 + \sin \gamma_2 + \cos \delta \sin \psi), \quad G_z' = H \sin \delta \end{aligned} \quad (6)$$

as may be easily seen from Fig.5 and Fig.7. The proper kinetic moments  $H_1$ ,  $H_2$  and  $H_3$  of the gyroscopes are considered to be equal to one and the same constant quantity  $H$ . Relations of the type (3), obtained by application of the theorem of the kinetic moments to the first mechanical system, are of the form:

$$\begin{aligned} \frac{dG_x'}{dt} + \omega_y G_z' - \omega_z G_y' &= M_x' \\ \frac{dG_y'}{dt} + \omega_z G_x' - \omega_x G_z' &= M_y' \\ \frac{dG_z'}{dt} + \omega_x G_y' - \omega_y G_x' &= M_z' \end{aligned} \quad (7)$$

\* In the framework of the precessional theory of gyroscopes the resultant vector of the set of these forces is zero, and, consequently, this set reduces to a couple of forces with moment  $M'$ .

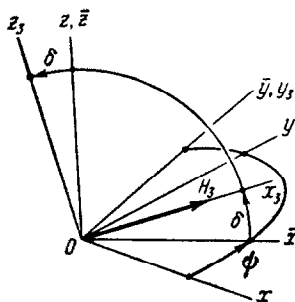

Fig. 7.

By analogy to the relation (5), the relation (Fig.3)

$$M_x' \cos \beta + M_z' \sin \beta = M_{x'} \tag{8}$$

represents the sum of the moments of forces acting on the first mechanical system, i.e. on the whole stabilizer with respect to the \$x'\$ (\$\xi\$)-axis of suspension of the ring K. This sum does not contain the moments of the normal reaction forces of the axle bearings, In this way the equality

$$\left[ \frac{dG_{x'}}{dt} + \omega_y G_z' - \omega_z G_y' \right] \cos \beta + \left[ \frac{dG_z'}{dt} + \omega_x G_y' - \omega_y G_x' \right] \sin \beta = M'_{x'} \tag{9}$$

obtained by replacement of \$M\_x\$, and \$M\_z\$, in the relation (8) by their expressions (7), appears as the equation of motion of the gyrostabilizer. This equation does not contain the above mentioned moments of the unknown normal reaction forces of the bearings of the axis of the ring K, located on the carrying support.\*

Using formulas (6) in the equality (9) and simplifying, we obtain the equation

$$\begin{aligned} H \left\{ \cos \beta \frac{d}{dt} \left( -\sin \gamma_1 + \cos \gamma_2 \right) - \cos \beta \cos \delta \sin \psi \left( \omega_z + \frac{d\psi}{dt} \right) - \right. \\ \left. - (\cos \beta \sin \delta \cos \psi - \sin \beta \cos \delta) \frac{d\delta}{dt} + \omega_y \left[ \cos \beta \sin \delta - \sin \beta \left( -\sin \gamma_1 + \right. \right. \right. \\ \left. \left. \left. + \cos \gamma_2 + \cos \delta \cos \psi \right) \right] + \left( \omega_x \sin \beta - \omega_z \cos \beta \right) \left( \cos \gamma_1 + \sin \gamma_2 \right) + \right. \\ \left. + \omega_x \sin \beta \cos \delta \sin \psi \right\} = M'_{x'} \tag{10} \end{aligned}$$

In addition to the moment of friction forces and the moment developed by the electromotor \$E\_1\$, the moment \$M'\_{x'}\$ contains the moments of the

\* Here and in what follows it is assumed that the moments of friction in all the axles of suspension do not depend on the magnitude of the normal reaction forces.

attraction forces of the Earth on the parts of the whole device and the moments of the inertia forces of the constrained motion, of the supporting coordinate system  $\xi^* \eta^* \zeta^*$  with its origin at the geometric center of suspension.

9. Equation (10) is one of the six differential equations describing the motion of a gyroscopic stabilizer. In order to obtain the next equation, consider the mechanical system, consisting, as the preceding one, of all the parts of the stabilizer, except the ring  $K$ . Since the kinetic moment of the ring  $K$  in the elementary theory of gyroscopes is not taken into account, the resultant kinetic moment  $G$  of this new system must be considered equal to the kinetic moment  $G'$  of the preceding system, i.e.

$$G_x = G_x', \quad G_y = G_y', \quad G_z = G_z' \quad (11)$$

where  $G_x$ ,  $G_y$  and  $G_z$  are the projections of the kinetic moment of the new system on the  $x$ -,  $y$ - and  $z$ -axis respectively, and  $G'_x$ ,  $G'_y$  and  $G'_z$  are determined by formulas (6).

The reaction forces of connection of the platform  $\Pi$  with the ring  $K$  appear in this system as external forces, and therefore must be taken into account in relations which follow from the kinetic moment theorem. These relations have the form of equalities (3). The normal components of the reaction forces are absent only in the middle equation of the set (3), because the  $y(y')$ -axis is at the same time also the axis of the platform  $\Pi$ ; the bearings of this axis are rigidly connected with the ring  $K$ . Making use of the equalities (11) and the formulas (6) we obtain the equation

$$H \left[ \frac{d}{dt} (\cos \gamma_1 + \sin \gamma_2) - \sin \delta \sin \psi \frac{d\delta}{dt} + \left( \omega_z + \frac{d\psi}{dt} \right) \cos \delta \cos \psi + \omega_z (-\sin \gamma_1 + \cos \gamma_2) - \omega_x \sin \delta \right] = M_y \quad (12)$$

The right-hand side of this equation, i.e. the moment  $M_y$  contains the moment of friction of the axis of the platform on its bearings, the reduced moment of the electromotor  $E_2$ , the moment of the gravitation forces and the inertia forces of the constrained motion of all the parts of the stabilizer, except the outer ring.

10. Consider now the third mechanical system, consisting of the body  $T$  with the gyroscope  $III$  (Fig.4). Its kinetic moment consists of the proper kinetic moment  $\tilde{G}$  of the gyroscope  $III$ . Consequently, (Fig.7), the projections of the vector  $\tilde{G}$  on the axes of the computational coordinate system  $xyz$  are given by the formulas

$$\tilde{G}_x = H \cos \delta \cos \psi, \quad \tilde{G}_y = H \cos \delta \sin \psi, \quad \tilde{G}_z = H \sin \delta \quad (13)$$

Of the three equations of the type (3) only the third must be used in the present case because the remaining equations contain the unknown normal reaction forces of the bearings on the axis of the body  $T$  to be stabilized. These forces are external with respect to the partial mechanical system under consideration. In this way, taking into account the formulas (13), we arrive at the equation

$$H \left( \cos \delta \frac{d\delta}{dt} + \omega_x \cos \delta \sin \psi - \omega_y \cos \delta \cos \psi \right) = \tilde{M}_z \quad (14)$$

Here  $\tilde{M}_z$  is the moment about the  $z(\bar{z})$ -axis of all the external forces acting on the third mechanical system, i.e. on the body  $T$ , the inner gimbal and the rotor of the gyroscope  $III$ , including the friction forces, the moment imposed by the electromotor  $E_3$ , and also the moments of the inertia forces and gravitation forces. As before, the inertia forces are defined as the inertia forces of the constrained motion, implied by the translatory motion of the supporting coordinate system  $\xi^*\eta^*\zeta^*$  with the origin at the geometric center of suspension of the stabilizer.

II. Considering the next three mechanical systems, i.e. the gyroscopes  $I$ ,  $II$  and  $III$ , the corresponding coordinate systems of support  $\xi_1^*\eta_1^*\zeta_1^*$ ,  $\xi_2^*\eta_2^*\zeta_2^*$  and  $\xi_3^*\eta_3^*\zeta_3^*$  must be chosen in such a way that their origins coincide with the points of intersection of the axes of the inner gimbal and the rotor of the corresponding gyroscope. They have different accelerations with respect to the absolute coordinate system  $\xi_a^*\eta_a^*\zeta_a^*$ . This difference is implied by the angular velocity  $\omega$  of the platform  $\Pi$ , and for the system of support  $\xi_3^*\eta_3^*\zeta_3^*$  also by the relative angular velocity  $d\psi/dt$  of the body  $T$  with respect to the platform  $\Pi$ . Because of the small dimensions of the gyroscopic stabilizer and the comparatively small magnitudes of  $\omega_x$ ,  $\omega_y$ ,  $\omega_z$  and  $d\psi/dt$ , the above mentioned difference of accelerations between the various coordinate systems of support and the system of support  $\xi^*\eta^*\zeta^*$  is very small and in practice, in the majority of cases, it can be neglected.

Applying the theorem of kinetic moment to the mechanical system consisting of the rotor and the inner gimbal of the gyroscope  $I$ , we obtain the equality

$$\frac{d}{dt} G_z^I + \omega_x G_y^I - \omega_y G_x^I = M_z^I \quad (15)$$

which is analogous to the third of the relations of the type (3) and which does not contain the unknown normal reaction forces of the axis of the inner gimbal. In the last equality (Fig.5)

$$G_x^I = -H \sin \gamma_1, \quad G_y^I = H \cos \gamma_1, \quad G_z^I = 0 \quad (16)$$

are the projections of the kinetic moment  $G^I$  of this system, or, what is the same, of the proper kinetic moment of the gyroscope  $I$  on the axes of the axes of the computational coordinate system  $xyz$ . The quantity  $M_{z1}^I$

denotes the sum of the moments with respect to the  $z_1$ -axis of the inner gimbal of all forces acting on the gimbal and the rotor of this gyroscope. To these forces belong, in particular, the friction forces of the axes of suspension of the inner gimbal, the gravitation forces, the inertia force of the constrained motion, the elastic forces of the electric wirings and the reaction forces of the servo-mechanisms  $D_1$  and  $D_2$ .

Using the formulas (16), the equality (15) assumes the form

$$H(\omega_x \cos \gamma_1 + \omega_y \sin \gamma_1) = M_{z_1}^I \quad (17)$$

This is the fourth equation of motion for the gyroscopic stabilizer.

Carrying out, in a similar way, calculations with respect to the gyroscope *II*, we obtain the fifth equation, namely

$$H(\omega_x \sin \gamma_2 - \omega_y \cos \gamma_2) = M_{z_2}^{II} \quad (18)$$

The moment  $M_{z_2}^{II}$  has the same meaning as the moment  $M_{z_1}^I$ , being the sum of moments of forces acting on the inner gimbal and the rotor of the gyroscope *II* with respect to the axis  $z_2$  of its inner gimbal.

It is essential that the equations (17) and (18) do not contain the unknown normal reaction forces of the bearings on the axes of the inner gimbals of the gyroscopes *I* and *II*.

12. Finally, consider the sixth mechanical system, consisting of the inner gimbal and the rotor of the gyroscope *III* (Fig.6). In this case the relations (3), after replacing the quantities  $G_x$ ,  $G_y$  and  $G_z$ , respectively, by the projections of the kinetic moment of the gyroscope *III*, namely

$$G_x^{III} = H \cos \delta \cos \psi, \quad G_y^{III} = H \cos \delta \sin \psi, \quad G_z^{III} = H \sin \delta \quad (19)$$

assume the form

$$\begin{aligned} H \left[ \frac{d}{dt} (\cos \delta \cos \psi) + \omega_y \sin \delta - \omega_z \cos \delta \sin \psi \right] &= M_x^{III} \\ H \left[ \frac{d}{dt} (\cos \delta \sin \psi) + \omega_z \cos \delta \cos \psi - \omega_x \sin \delta \right] &= M_y^{III} \\ H \left[ \frac{d}{dt} \sin \delta + (\omega_x \sin \psi - \omega_y \cos \psi) \cos \delta \right] &= M_z^{III} \end{aligned} \quad (20)$$

Here  $M_x^{III}$ ,  $M_y^{III}$  and  $M_z^{III}$  are the sums of the moments of forces acting on the inner gimbal and the rotor of the gyroscope *III*, calculated with respect to the axes  $x, y$  and  $z$  (or, with respect to the axes, respectively parallel to the axes  $x, y$  and  $z$ ; see footnote in Section 6).

Among these forces are also the unknown normal reaction forces of the bearings on the axis of the inner gimbal of the gyroscope *III*, located in the body *T*. However, if we consider the expression

$$-M_x^{III} \sin \psi + M_y^{III} \cos \psi = M_{\tilde{y}}^{III} \quad (21)$$

then it is not difficult to see that it gives the sum of the moments of forces acting on the gyroscope III and calculated with respect to the axis  $\tilde{y}$  of its inner gimbal, and that the above mentioned normal reaction forces are not present in this expression. Substituting in this expression for  $M_x^{III}$  and  $M_y^{III}$  their expressions according to the equalities (20), we obtain after some calculations the equation

$$H \left[ \left( \omega_z + \frac{d\psi}{dt} \right) \cos \delta - (\omega_x \cos \psi + \omega_y \sin \psi) \sin \delta \right] = M_{\tilde{y}}^{III} \quad (22)$$

Let us note that, in deriving the equations (17), (18) and (22), instead of the computational coordinate system  $xyz$ , also other computational systems can be used, in particular the system  $\tilde{x}\tilde{y}\tilde{z}$ , in deriving the equation (22).

Equation (22) completes the set of six differential equations describing the behavior of a gyroscopic stabilizer and its separate parts among each other and with respect to directions connected with the fixed stars.

13. For the convenience of the subsequent conclusions let us collect together the equations (10), (12), (14), (17), (18), and (22). We then obtain the following set of equations

$$\begin{aligned} & H \left\{ \cos \beta \left[ \frac{d}{dt} (-\sin \gamma_1 + \cos \gamma_2) - \cos \delta \sin \psi \left( \omega_z + \frac{d\psi}{dt} \right) + \omega_y \sin \delta \right] - \right. \\ & \left. - \left( \cos \beta \sin \delta \cos \psi - \sin \beta \cos \delta \right) \frac{d\delta}{dt} + \sin \beta \left[ \omega_x \cos \delta \sin \psi - \omega_y (-\sin \gamma_1 + \right. \right. \\ & \left. \left. + \cos \gamma_2 + \cos \delta \cos \psi) \right] + (\omega_x \sin \beta - \omega_z \cos \beta) (\cos \gamma_1 + \sin \gamma_2) \right\} = M_{x'} \\ & H \left[ \frac{d}{dt} (\cos \gamma_1 + \sin \gamma_2) - \sin \delta \sin \psi \frac{d\delta}{dt} + \left( \omega_z + \frac{d\psi}{dt} \right) \cos \delta \cos \psi + \omega_z (-\sin \gamma_1 + \right. \\ & \left. + \cos \gamma_2) - \omega_x \sin \delta \right] = M_y \\ & H \left( \cos \delta \frac{d\delta}{dt} + \omega_x \cos \delta \sin \psi - \omega_y \cos \delta \cos \psi \right) = \tilde{M}_z \\ & H (\omega_x \cos \gamma_1 + \omega_y \sin \gamma_1) = M_{z_1}^I, \quad H (\omega_x \sin \gamma_2 - \omega_y \cos \gamma_2) = M_{z_2}^{II} \\ & H \left[ \left( \omega_z + \frac{d\psi}{dt} \right) \cos \delta - (\omega_x \cos \psi + \omega_y \sin \psi) \sin \delta \right] = M_{\tilde{y}}^{III} \end{aligned} \quad (23)$$

describing the motion of a gyroscopic stabilizer with three axes.

14. Consider some important consequences of these equations. Let

$$M_{z_1}^I = M_{z_2}^{II} = M_{\tilde{y}}^{III} = 0 \quad (24)$$

i.e. the projections of the moments on the axes of the inner gimbals of the gyroscopes are zero. In practice this can be achieved to some extent as a result of a careful balancing of the gyroscopes so that the center of gravity of the system consisting of the inner gimbal and the rotor lies as close as possible to the axis of the corresponding inner gimbal, and the friction forces in the bearings and the resistance of the wirings are reduced to a minimum.

According to the fourth and fifth equation of (23) we obtain in this case the equalities

$$\omega_x \cos \gamma_1 + \omega_y \sin \gamma_1 = 0, \quad \omega_x \sin \gamma_2 - \omega_y \cos \gamma_2 = 0 \quad (25)$$

from which it follows that

$$\omega_x = \omega_y = 0 \quad (26)$$

in all cases except

$$\gamma_2 = \gamma_1 \pm 1/2\pi \quad (27)$$

when the axes of spin of the gyroscopes *I* and *II* are parallel. Thus, if as a result of action of the electromotors  $E_1$  and  $E_2$  the angles  $\gamma_1$  and  $\gamma_2$  remain between certain limits, for example, between  $\pm 15^\circ$  and  $20^\circ$ , then the plane of the platform  $\Pi$  under conditions (24) will turn out to be stabilized with respect to the fixed stars.

The sixth equation of the system (23), taking into account the conditions (24) and equalities (25) reduces to

$$\omega_z + \frac{d\psi}{dt} = 0 \quad (28)$$

provided, of course,

$$\delta \neq \pm 1/2\pi \quad (29)$$

The left-hand side of equality (28) is the projection on the  $z(\bar{z})$ -axis of the angular velocity of the body *T* with respect to the coordinate system of support  $\xi^*\eta^*\zeta^*$ . The projections of this angular velocity on the  $x$ - and  $y$ -axis coincide with the corresponding projections of the angular velocity of the platform  $\Pi$ , and because of the equalities (26), are equal to zero. Thus, if the projections of the moments on the axes of the inner gimbals of all three gyroscopes are zero, i.e. if the conditions (24) are satisfied, the body *T* turns out to be stabilized with respect to direction to fixed stars.

The first three equations (23), taking into account the equalities (26) and (28) assume the form

$$-H \cos \beta \left[ \frac{d}{dt} (\sin \gamma_1 - \cos \gamma_2) + (\sin \delta \cos \psi - \cos \delta \operatorname{tg} \beta) \frac{d\delta}{dt} + \omega_z (\cos \gamma_1 + \sin \gamma_2) \right] = M_x' \quad (30)$$



$$H \left[ \frac{d}{dt} (\cos \gamma_1 + \sin \gamma_2) - \sin \delta \sin \psi \frac{d\delta}{dt} + \omega_z (-\sin \gamma_1 + \cos \gamma_2) \right] = M_y$$

$$H \cos \delta \frac{d\delta}{dt} = \tilde{M}_z$$

Under the assumption that no moments are applied to the ring  $K$ , the platform  $\Pi$  and the body  $T$ , and that the friction is absent, i.e.

$$M'_{x'} = M_y = \tilde{M}_z = 0 \tag{31}$$

and that the motion of the carrying basis is such that

$$\omega_z = 0 \tag{32}$$

the equations (30) are satisfied by arbitrary constant values of the angles  $\gamma_1$ ,  $\gamma_2$  and  $\delta$ .

Let now the electromotors  $E_1$ ,  $E_2$  and  $E_3$  be directed in such a way that the moments, imposed by them on the axes of the ring  $K$ , the platform  $\Pi$  and the body  $T$ , be proportional to the angles of rotation of the inner gimbals of the corresponding gyroscopes, and let the friction in the axes of suspension as before be absent. In such a case we can assume that

$$M'_{x'} = k\gamma_1, \quad M_y = -k\gamma_2, \quad \tilde{M}_z = -k\delta \tag{33}$$

where  $k$  is a coefficient of proportionality.

Equations (30), under condition (32), have a solution

$$\gamma_1 = 0, \quad \gamma_2 = 0, \quad \delta = 0 \tag{34}$$

It is not difficult to convince oneself, remaining in the framework of the precessional theory of the gyroscopic stabilizer under consideration, that the equilibrium position determined by this solution is stable. In fact, if the angles  $\gamma_1$ ,  $\gamma_2$  and  $\delta$  are small, then up to the first order terms with respect to these quantities and their derivatives, the equations (30), taking into account the equalities (32) and (33), reduce to the form

$$-\cos \beta H \frac{d\gamma_1}{dt} = k\gamma_1 - \sin \beta H \frac{d\delta}{dt}, \quad H \frac{d\gamma_2}{dt} = -k\gamma_2, \quad H \frac{d\delta}{dt} = -k\delta \tag{35}$$

From these equations it is evident that the magnitudes of the angles  $\gamma_1$ ,  $\gamma_2$  and  $\delta$  will tend to zero independently from the law of change of the angle  $\beta$  between the planes of the ring  $K$  and the platform  $\Pi$ . The change of the latter is determined by the motion of the basis. We must assume, of course, that  $\beta < 90^\circ$ .\*

\* In some cases, with the motors switched on, the transient processes mentioned in Section 1 do not die out but lead to self-oscillations of the gyroscopic platform (first of all about the axis  $x'$  of the

Footnote continued overleaf:-

In a more general case the right-hand sides of the equations (30), i.e. the moments  $M'_{x'}$ ,  $M_y$  and  $\bar{M}_z$  contain, besides the moments of the electromotors, the moments of friction in the suspension axes  $x'(\xi)$ ,  $y(y')$  and  $z(z)$  of the ring  $K$ , the platform  $\Pi$  and the body  $T$  respectively. The directions of these axes are determined by the relative angular velocities  $d\alpha/dt$ ,  $d\beta/dt$  and  $d\psi/dt$ . In addition, in the case of an insufficient balancing of a mechanical system and its separate parts,  $M'_{x'}$ ,  $M_y$  and  $\bar{M}_z$  will contain also the moments of inertia forces of the constrained motion and of the gravity forces.

Under the assumption that the angles  $\gamma_1$ ,  $\gamma_2$  and  $\delta$  are small, the equations (30) reduce to the form

$$\begin{aligned} -\cos\beta H \left[ \frac{d\gamma_1}{dt} - \operatorname{tg}\beta \frac{d\delta}{dt} + \omega_z(1 + \gamma_2) \right] &= M_{x'}^* + M(\gamma_1) \\ H \left[ \frac{d\gamma_2}{dt} + \omega_z(1 - \gamma_1) \right] &= M_y^* - M(\gamma_2) \\ H \frac{d\delta}{dt} &= M_z^* - \tilde{M}(\delta) \end{aligned} \quad (36)$$

where  $M_{x'}^*$ ,  $M_y^*$  and  $\bar{M}_z^*$  are the above-mentioned sums of the moments of the friction forces, inertia forces and gravity forces, acting on the mechanical systems consisting of (a) the ring  $K$ , platform  $\Pi$  and the body  $T$  (with the gyroscopes  $I$ ,  $II$  and  $III$ ); (b) the platform  $\Pi$  and the body  $T$  (also with the gyroscopes  $I$ ,  $II$  and  $III$ ) and (c) only of the body  $T$  (with the gyroscope  $III$ ), respectively. The quantities  $M(\gamma_1)$ ,  $M(\gamma_2)$  and  $M(\delta)$  are the moments, imposed on these mechanical systems by the electromotors  $E_1$ ,  $E_2$  and  $E_3$ , respectively.

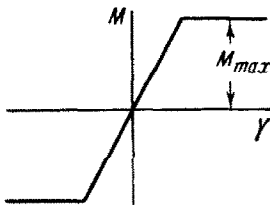

Fig. 8.

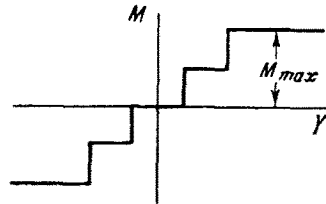

Fig. 9.

suspension ring  $K$ ). Investigating these oscillations, as well as the means of their suppression, one must take into account the moments of inertia of the parts of a gyroscopic device, and the transient processes in electric circuits of the motor and in the supplementary circuits of feedback of the amplifiers. Because of the high frequency of the self-oscillations, the influence of the motion of the basis on the oscillations, as a rule, turns out to be inessential. A discussion of self-oscillations of the described gyroscopic stabilizer is a subject of a separate investigation.

The moment, developed by each of the electromotors, cannot exceed a certain limit determined by the parameters of the motors and the transmission connecting its shaft with the corresponding axle. Fig. 8 illustrates a frequently encountered form of a diagram showing the dependence of the moment  $M$  developed by the motor (in a short circuit, i.e. for a completely checked motor) and the angle of deviation  $\gamma$  of the inner gimbal of a gyroscope from its mean position. In Fig. 9 another form of this dependence, the so-called step-form, is illustrated. For the successful working of a stabilizer it is absolutely necessary that the maximum moment  $M_{\max}$  for arbitrary circumstances of motion of the objects and the gyroscopic stabilizer exceeds the corresponding "destabilizing" moment  $M'_{x^*}$ ,  $M_y^*$  or  $\tilde{M}_{z^*}$ . In exactly the same way this moment must exceed the product

$$(\omega_z)_{\max} H \quad (37)$$

where  $(\omega_z)_{\max}$  is the maximum value of the angular velocity of the rotating platform  $\Pi$  about the  $z$ -axis, this rotation being implied by the motion of the object with circulation. If this is not the case, when turning the platform, the axes of spin of the gyroscopes  $I$  and  $II$  will fall behind this platform and the angles  $\gamma_1$  and  $\gamma_2$  will begin to increase without bound.

Conditions were established above under which the body  $T$  will be stabilized with respect to directions to the fixed stars. These conditions reduce to the requirement that the sum of moments of forces acting on each of the mechanical systems, consisting of the inner gimbal and the rotor, and calculated with respect to the axis of the corresponding gimbal, must be equal to zero. This can be realized only if the moments of friction in the bearings of the axis of the inner gimbal are completely removed and if the center of gravity of the system, consisting of the inner gimbal and the rotor, lies on the axis of this gimbal.

In a number of cases it is required that the body  $T$  is stabilized with respect to a coordinate system connected with the vertical of the location and the cardinal points of a specified geographical coordinate system. The axes of such a coordinate system, usually, are directed to the East, North and the Zenith respectively. In the case of a fixed basis the angular velocity of the body  $T$  must be equal to the angular velocity of the Earth. If, however, the basis is displaced, then the angular velocity of the body  $T$  must be equal to the sum of the angular velocity of the Earth and the angular velocity of the relative motion of the geographical coordinate system with respect to the Earth.

To the axes of the inner gimbals of the gyroscopes  $I$ ,  $II$  and  $III$ , in conformity with the last three equations of (23), must be applied the corresponding moments  $M_{z1}^I$ ,  $M_{z2}^{II}$  and  $M_y^{III}$ , causing the necessary

precession of the gyroscopes and, as a consequence of this, the necessary angular velocity of the body  $T$ . One of the methods for constructing the moments  $M_{z1}^I$  and  $M_{z2}^{II}$  was described in the footnote of Section 6. The technical realization of this problem, in case the basis is displaced, is faced with great difficulties.

## BIBLIOGRAPHY

1. Krylov, A.N. and Krutkov, Iu.A., *Obshchaia teoriia giroskopov i nekotorykh tekhnicheskikh ego primeneniia* (*General Theory of Gyroscopes and Some of Its Technical Applications*). Leningrad, 1932.
2. Grammel, R., *Giroskop, ego teoriia i primeneniia* (*The Gyroscope, its Theory and Applications*). IL, Moscow, 1952.
3. Ishlinskii, A.Iu., *Mekhanika special'nykh giroskopicheskikh sistem* (*Mechanics of special gyroscopic systems*). Akad. Nauk Ukr. SSR, Kiev, 1952.

Translated by E.L.